

AP Briquetting Presses

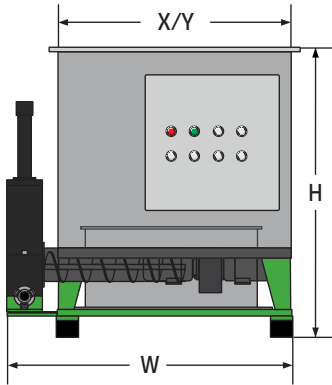

Technical Data



Type*	L	W	H	X	Y	S
AP 440	1900	1315	1410	1000	1000	200
AP 555	1900	1315	1410	1000	1000	200
AP 755	1900	1315	1410	1000	1000	200
AP 575	2210	1965	1435	1400	1400	200
AP 675	2210	1965	1435	1400	1400	200
AP 775	2210	1965	1435	1400	1400	200
AP 811	2210	1965	1435	1400	1400	200

* All dimensions are in millimeters

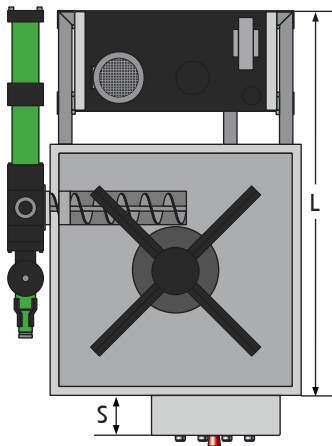

Type	Motor kW	Briquette Ø mm	Throughput* kg/h	Weight** kg
AP 440	4	40	40	850
AP 555	5,5	50	50	870
AP 755	7,5	70	70	900
AP 575	7,5	50	80-100	1050
AP 675	7,5	60	100-120	1100
AP 775	7,5	70	120-160	1200
AP 811	11	80	150-200	1800

*material dependent

**equipment dependent

Standard equipment:

Pressing mechanism with press, expletive and tong cylinders, press chamber wear bushings (except model AP11110), chrome plated tongs, container with base plate, tube extruder, motor, conveyer channel, discharge screw conveyor, ground frame with oscillating unit, hydraulic tank with pump motor and valve control, switching box including SPS control.